

HelloDevice Application Note

HelloDevice

Sena Technologies

HelloDevice



HelloDevice

, HelloDevice

10 Base -T

HelloDevice

-
-
-

. HelloDevice

가 .

HelloDevice



- H/W

- HelloDevice

IO DPRAM

- Serial

Serial

-

DPRAM

IO Relay DPRAM

- S/W

- Web Server

Web

TCP

- HelloDevice

- Serial

Ethernet

Serial

HelloDevice



1. Sena Demoroom – HD1100
2. Sena DemoBox – HD1100, HD1200, HD1300
3. Network Camera – HD1200
4. 가 POS System – HD1300
5. – HD2310E(PPP)

	Model	Web	Server / Client
Sena Demoroom	HD1100		Server
Sena DemoBox	HD1100,1200,1300		Server
Network Camera	HD1200		Server
가 POS System	HD1300		Server
	HD2310		Client

Sena Demoroom

- : Home Automation Demo
- : HD 1100(16 Input/16 Output)

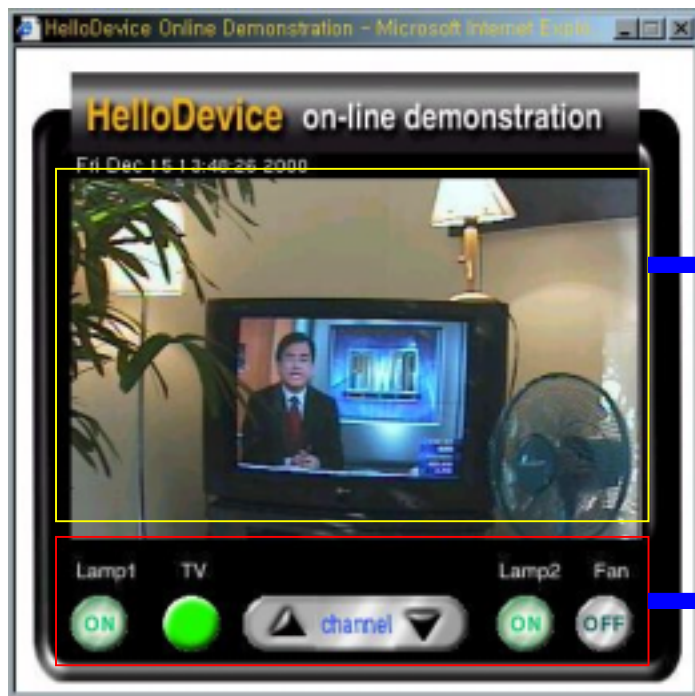

Web Camera

Demoroom

HelloDevice

Control Panel.

가 Lamp1, Lamp2, Fan TV
On/Off

Sena Demoroom

-

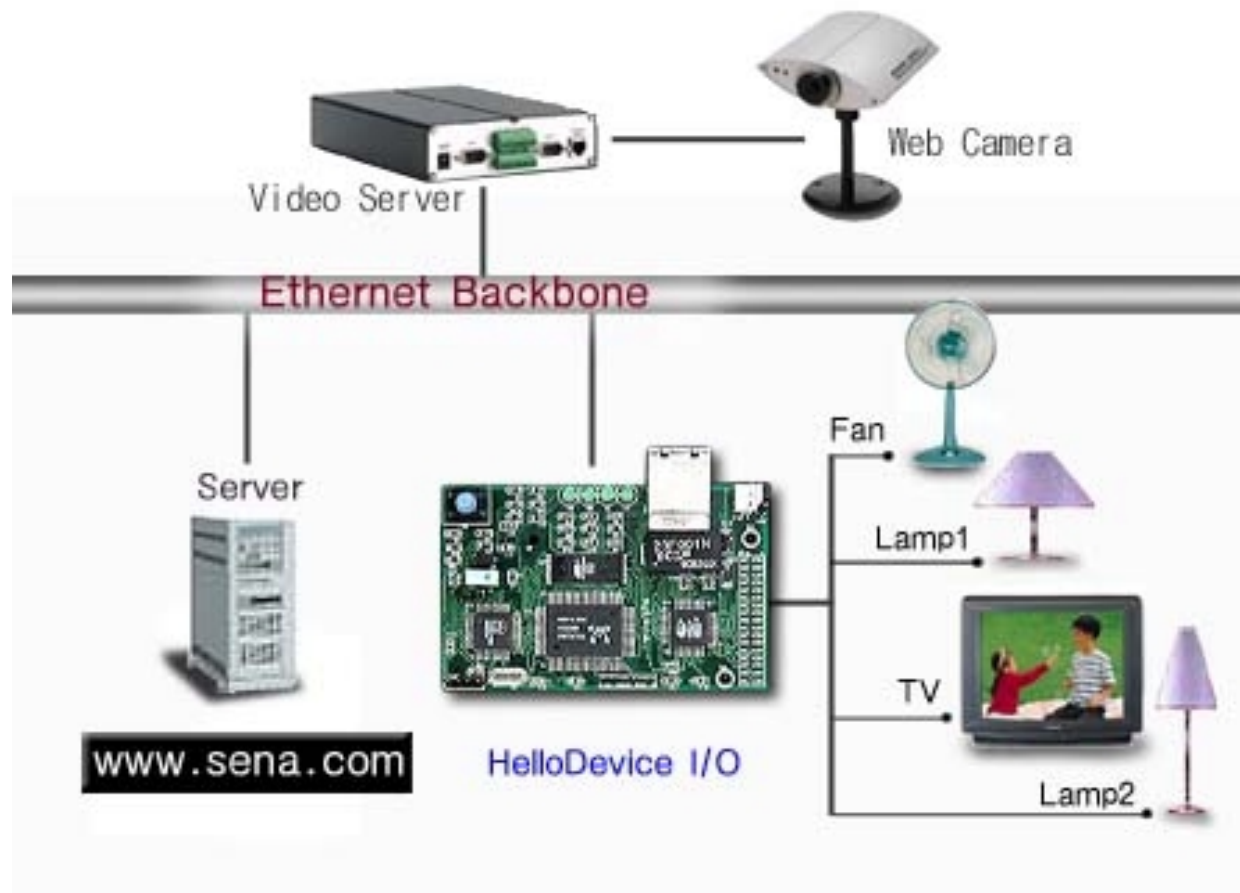

Sena Demoroom

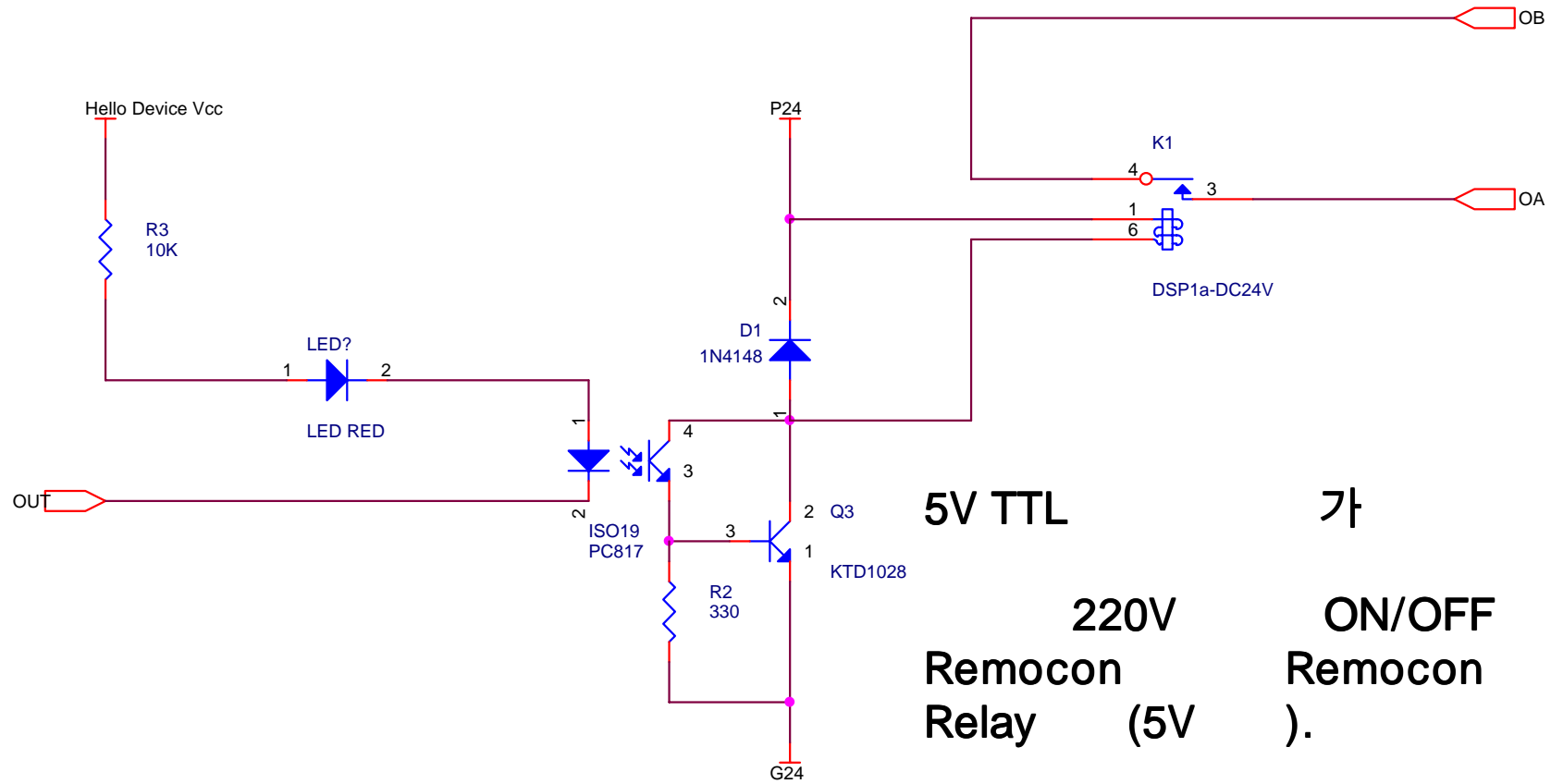

Sena Demobox



- : HelloDevice
 - Remote On/Off Control & Sensing : HD1100
 - Remote Data Gathering : HD1200
 - Remote Display : HD1300
- :
On/Off , , Gathering,
Display .

Sena Demobox

- Sena Technologies DemoBox

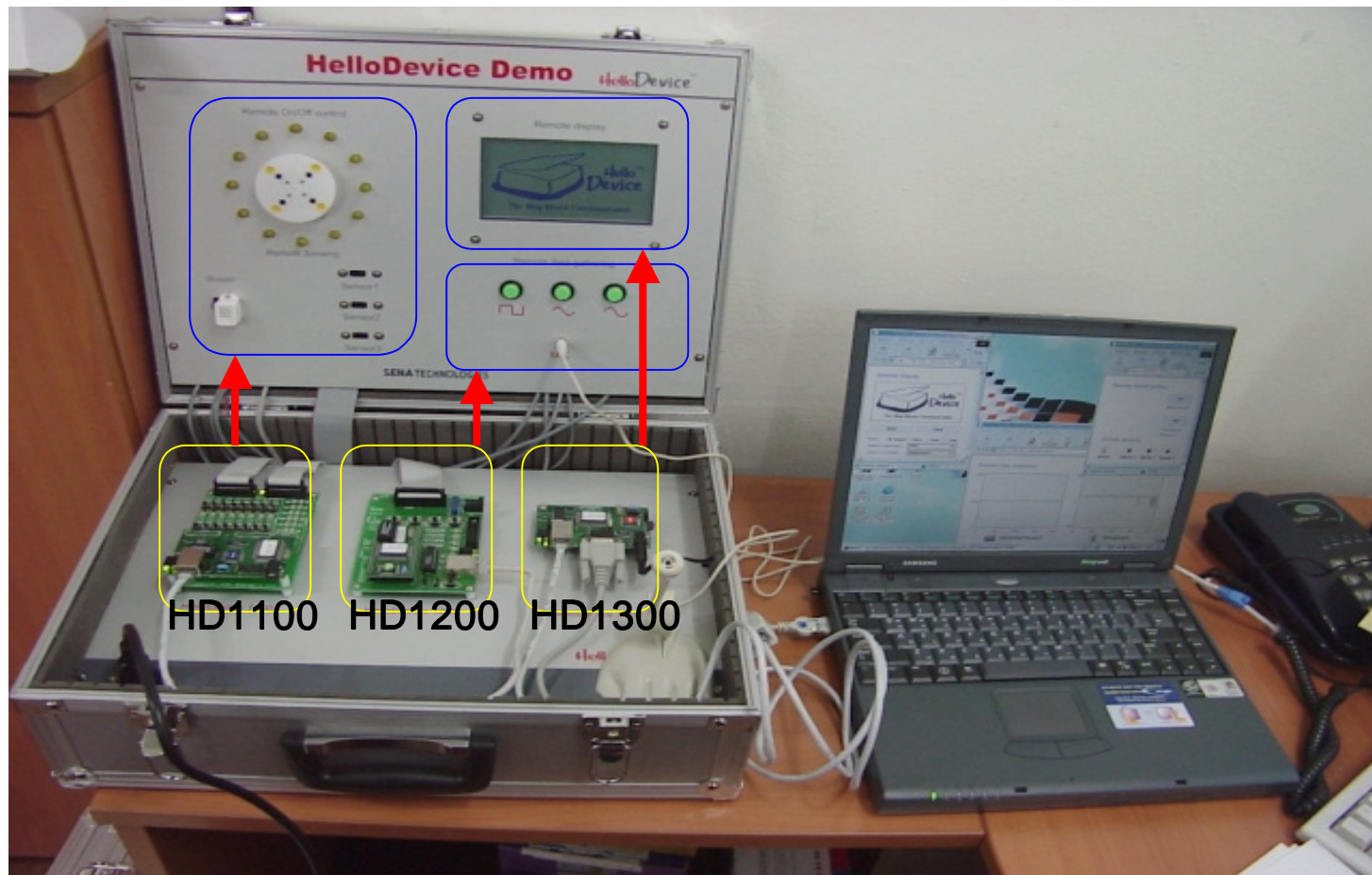

Sena Demobox

- Remote On/Off Control & Remote Sensing

Remote On/Off Control

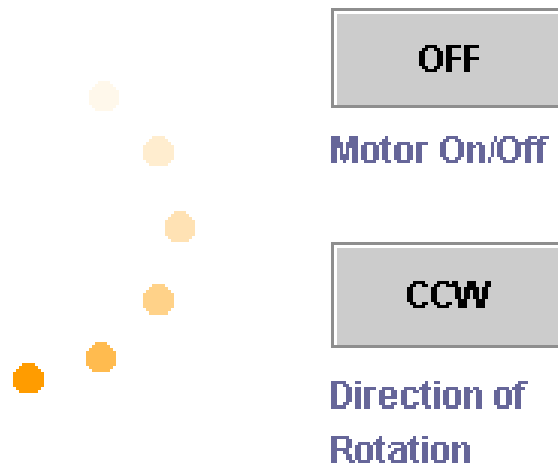

: Motor On Output
Led가

On/OFF, CW/CCW, LED
- 14EA Output

Remote Sensing



: Sensor Input 가
Output

Buzzer
Sensor - 3EA Input,
Buzzer - 1EA Output

Sena Demobox



- Remote On/Off & Sensing

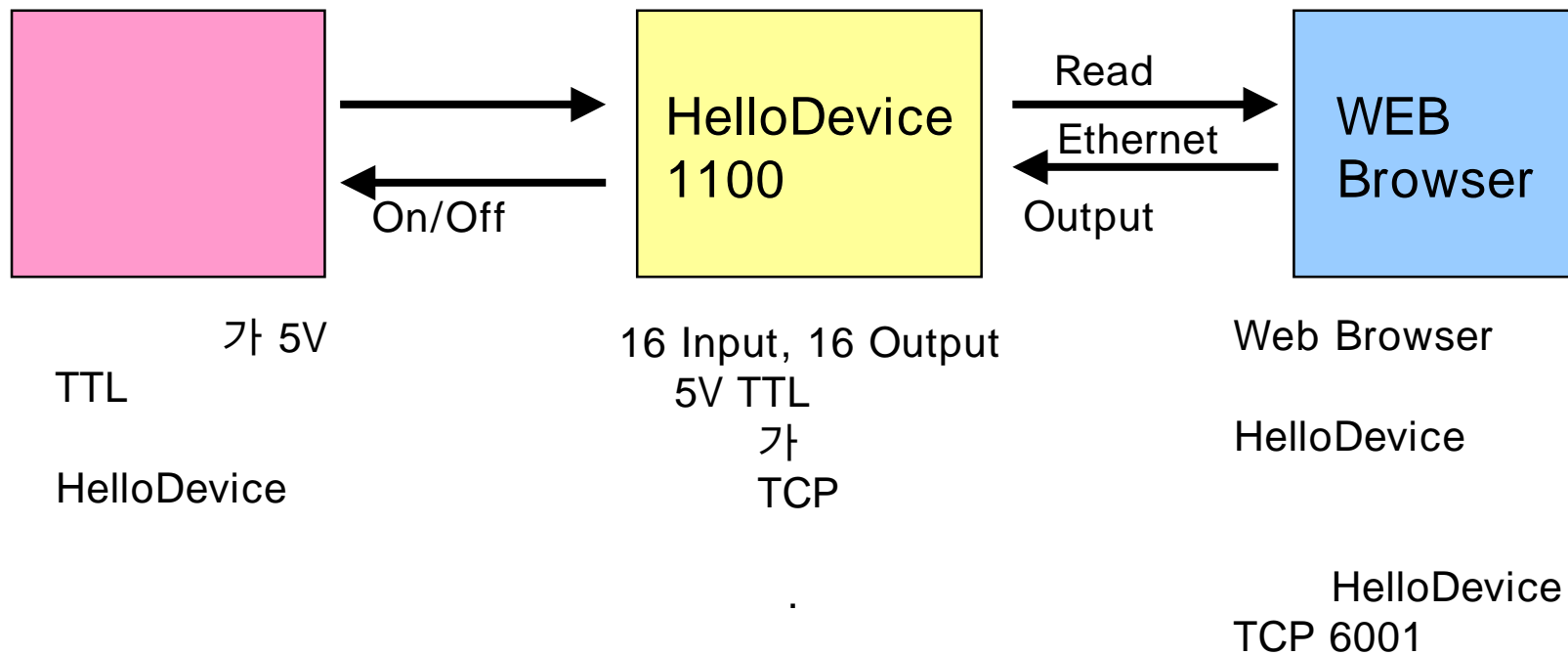

Sena Demobox

- Remote On/Off Control & Remote Sensing

- Schematic

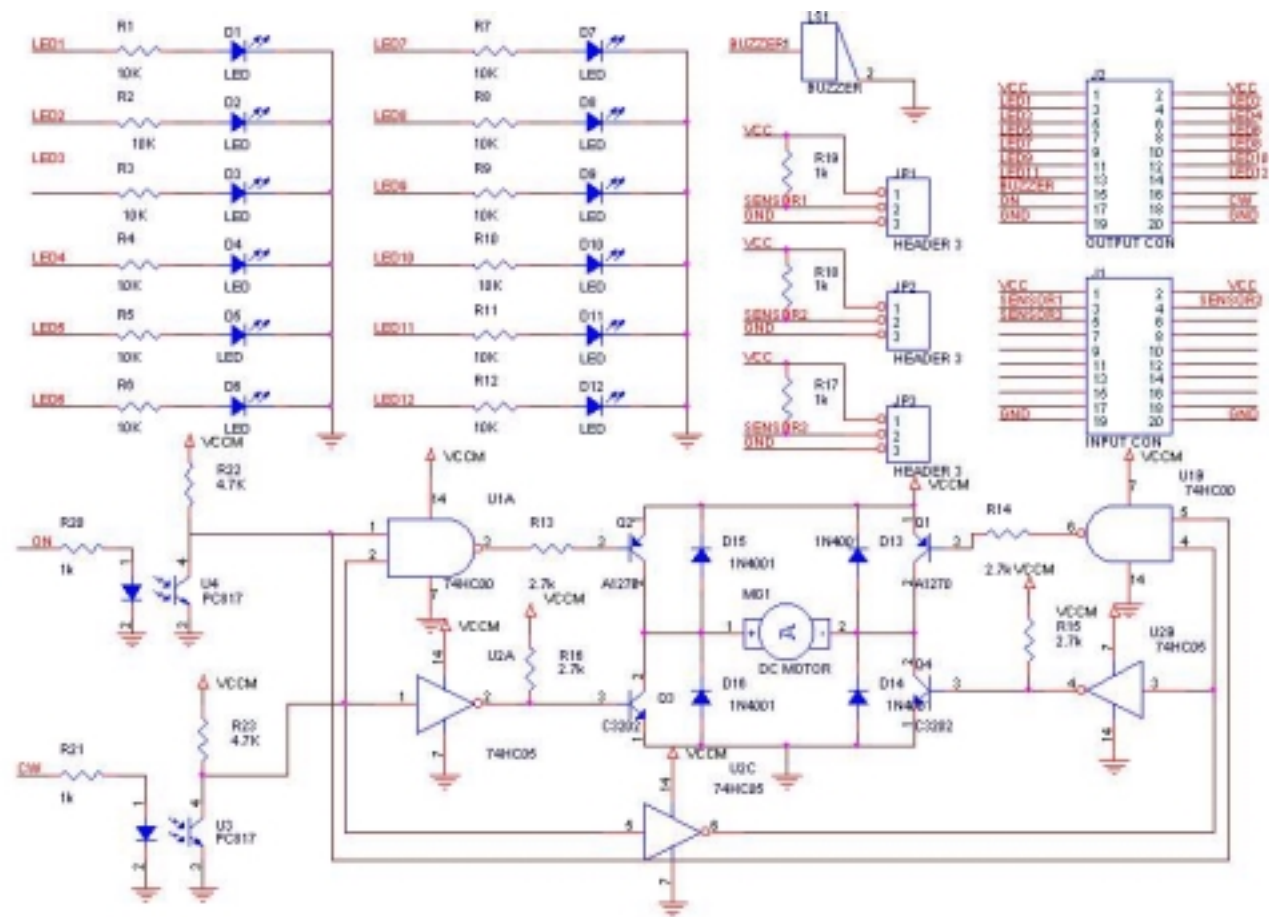

Sena Demobox

- Remote Data Gathering

Remote Data Gathering

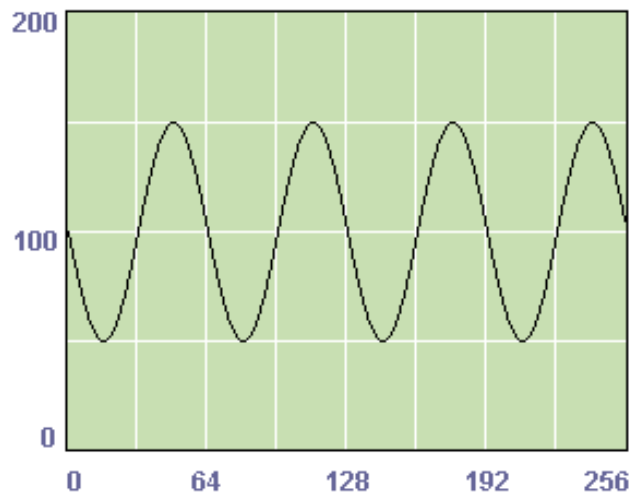

Generated function

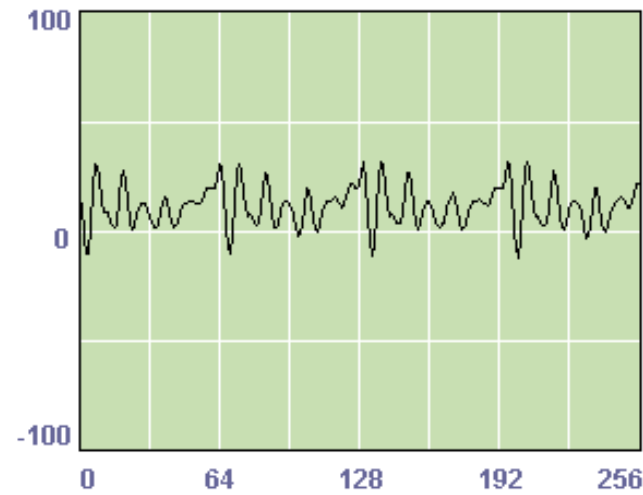

Microphone

Generated Function

-

Microphone

- Microphone

DPRAM

Analog

ADC

DPRAM

.

Digital

.

Sena Demobox

- Remote Data Gathering

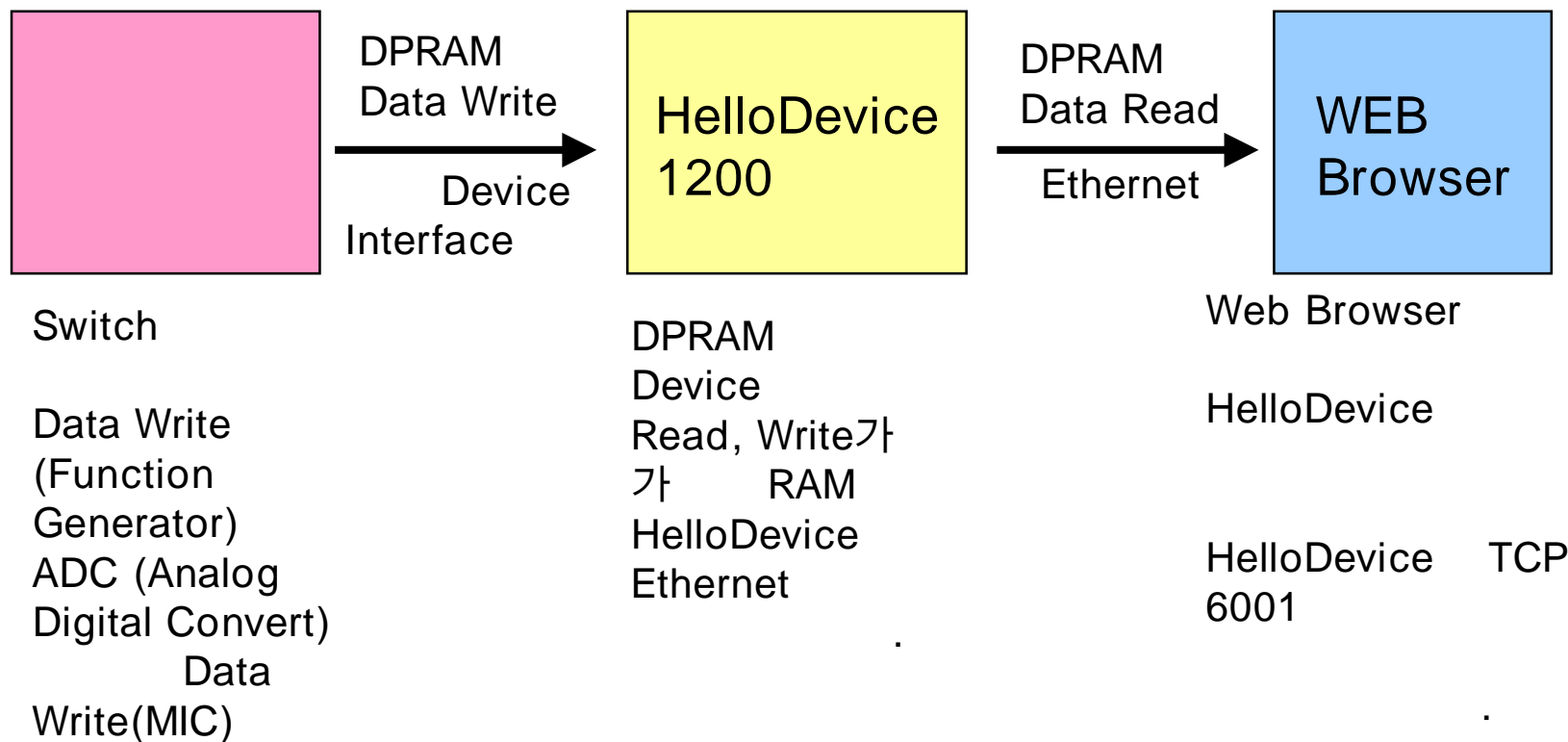

Sena Demobox

- Remote Data Gathering
- Schematic

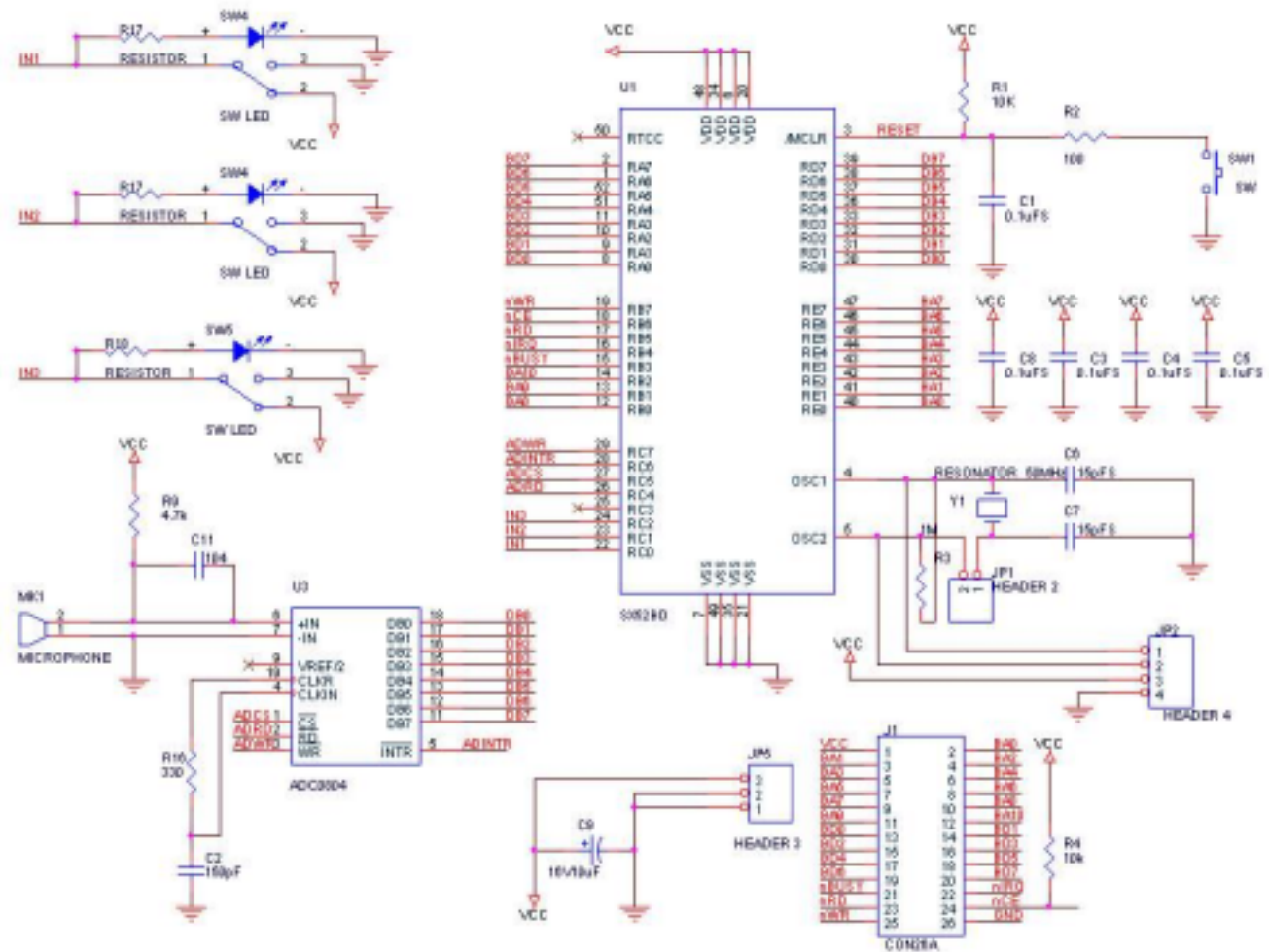

Sena Demobox



•Remote Data Gathering Source(SX52BD)

- DPRAM Write – DPRAM 1Byte Write

```
_dpramwrite
    mov     Scratch0, w
    bank52  DPRAMVars
    mov     !dataLo, #00
    mov     addLo, DPROffsetLSB
    mov     addHi, DPROffsetMSB
    nop
    mov     dataLo, Scratch0
    nop
    clrb    dpramcs
    nop
    clrb    rw
    nop
    setb    rw
    nop
    setb    dpramcs
    nop
    retp
```

- Dpram Read – DPRAM 1Byte Read

```
_dpramread
    bank52  DPRAMVars
    mov     !dataLo, #FF
    mov     addLo, DPROffsetLSB
    mov     addHi, DPROffsetMSB
    nop
    setb    rw
    nop
    clrb    dpramcs
    nop
    mov     Scratch0, dataLo
    nop
    setb    dpramcs
    nop
    mov     w, Scratch0
    retp
```

Sena Demobox



- ADC Read – ADC Digital
- Draw ADC – DPRAM Write

```

_read_adc      mov     !addata,#$FF
               clr b   adintr
               nop
               clr b   adcs
               nop
               clr b   adrw
               call   delay300
               setb   adintr
               call   delay300
               setb   adrw
               nop
               mov     w, addata ;ADC Read
               mov     adpdata, w
               setb   adcs
               nop
               mov     w, adpdata
               retp
    
```

```

Draw_adc      mov     dpradd, #$00
               setb   add8
               ;DPRAM ADC Address SET
:adc_read     call   @start_adc
               call   @read_adc
               nop
               nop
               mov     Scratch0, w
               mov     DPROffsetLSB, dpradd
               call   @dpramwrite
               csne   dpradd, #$FF
               jmp     :exit_adc
               inc    dpradd
               jmp     :adc_read
:exit_adc     clr b   add8
               jmp     _start
    
```

Source file

Sena Demobox



- Remote Display

Remote Display



Item : Pencil Rect Oval Text

Select a pen type :

Select an Image :

Connection Status : Connected

Select an image click
menu
Web

Serial

Send
Popup
Graphic LCD

Sena Demobox



- Remote Display

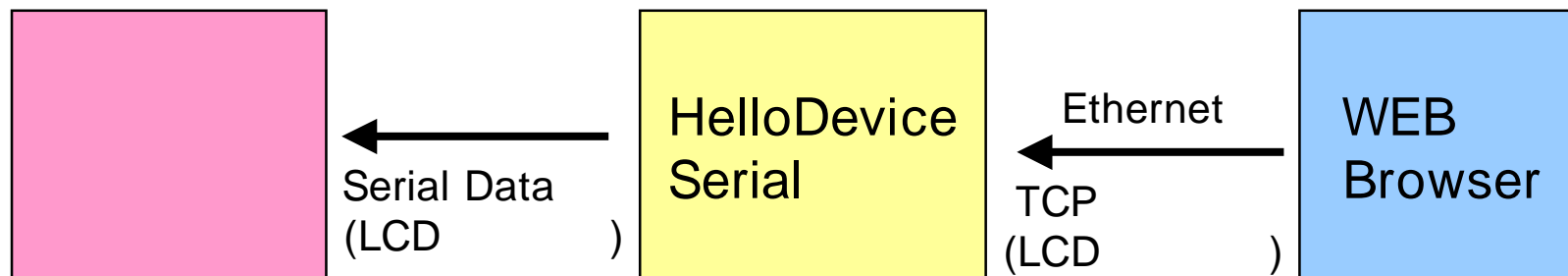

Serial (RS -232C) 가 Serial (LCD) Display LCD .)

TCP . TCP 가 HelloDevice TCP 6001

Web Browser HelloDevice

Sena Demobox

- Remote Display
 - Schematic : Lcd Display

5V RX

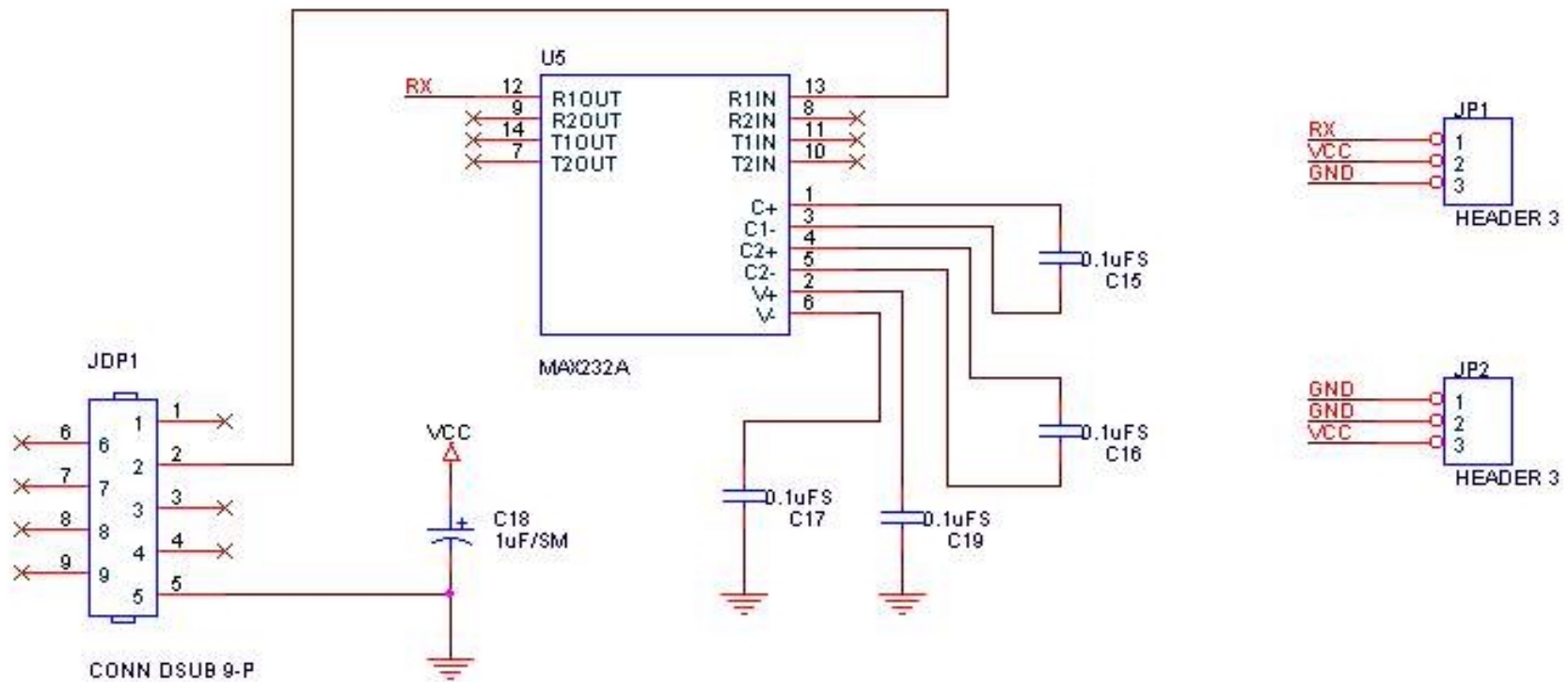

Network Camera

- : 가 Network Camera Server .
- : HD1200(DPRAM)



< >



< S/W >

Network Camera

- (Home Automation & Monitoring)

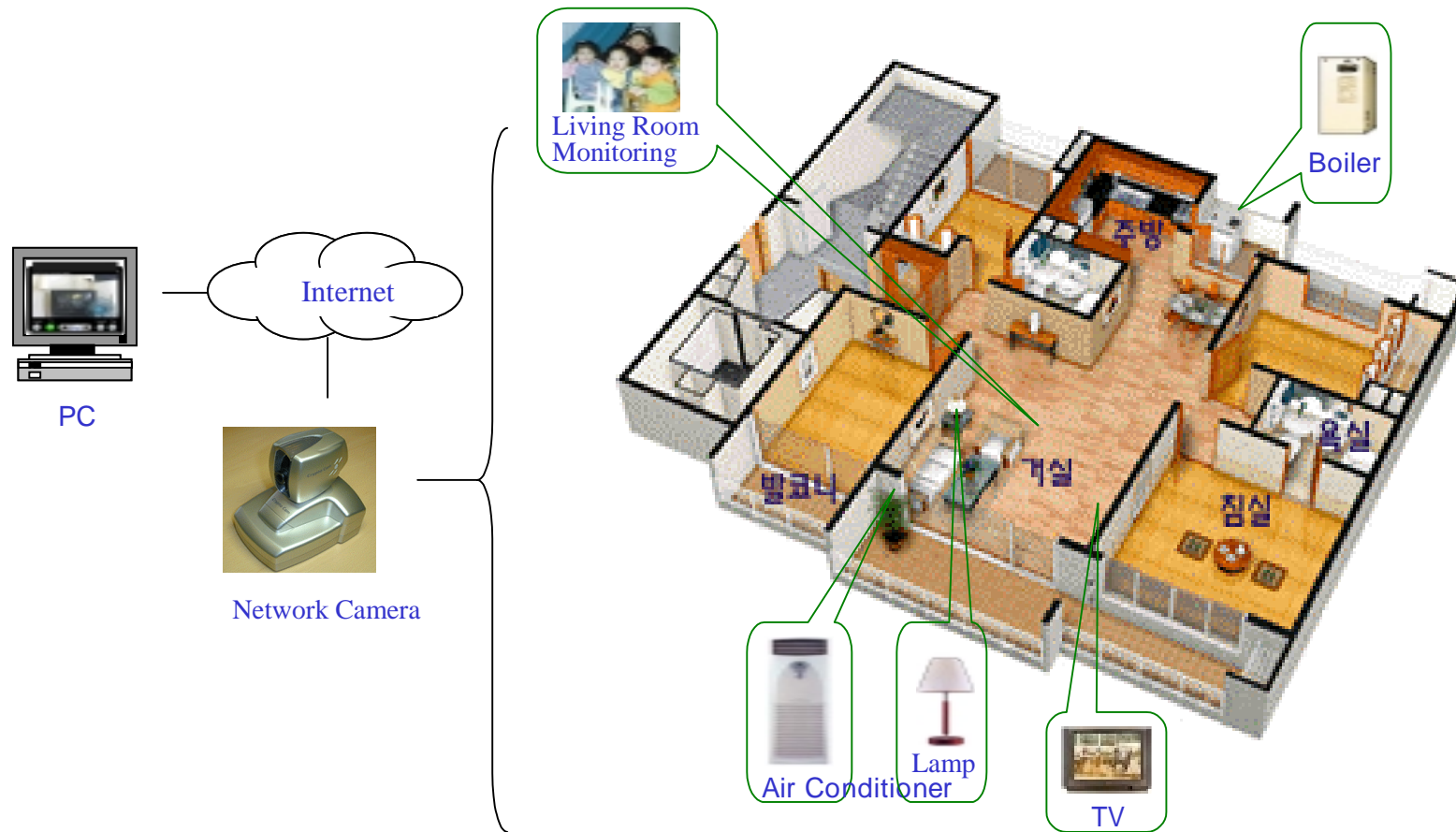

Network Camera

- H/W

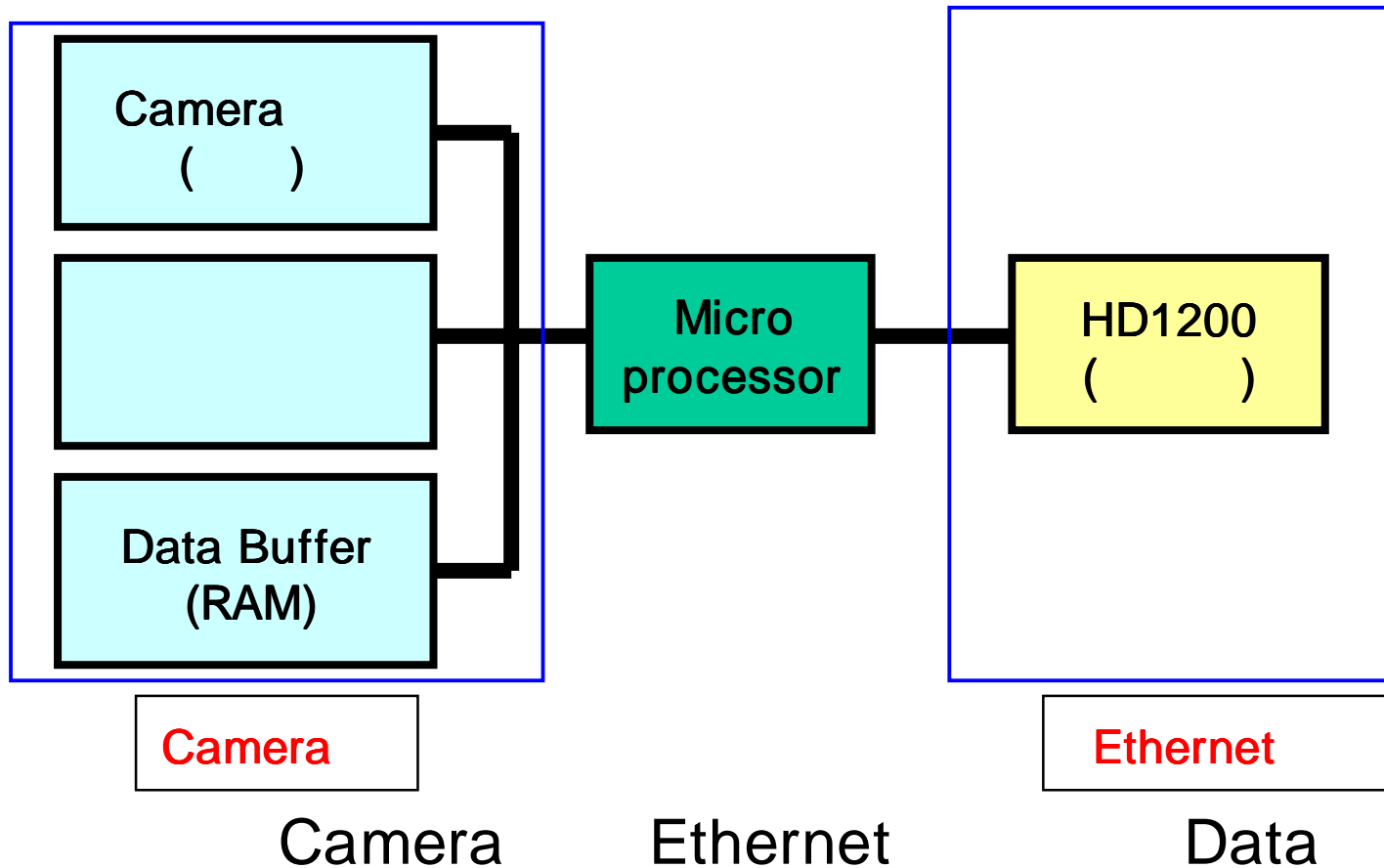

- Camera Ethernet Data

Network Camera

- - DPRAM

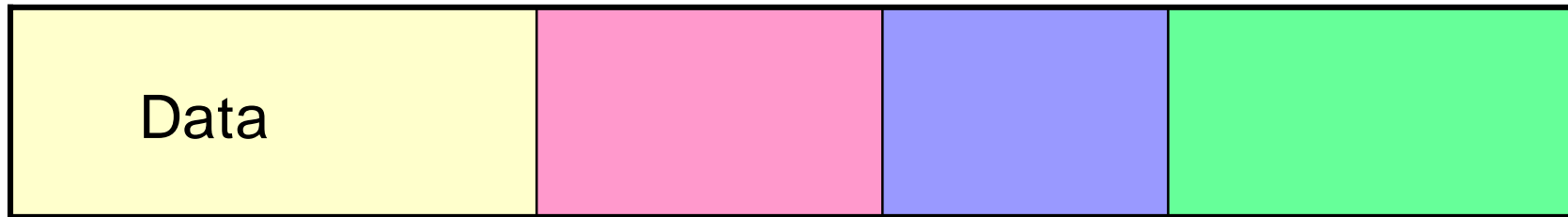

- HelloDevice

-

Network Camera

- - Data Flow

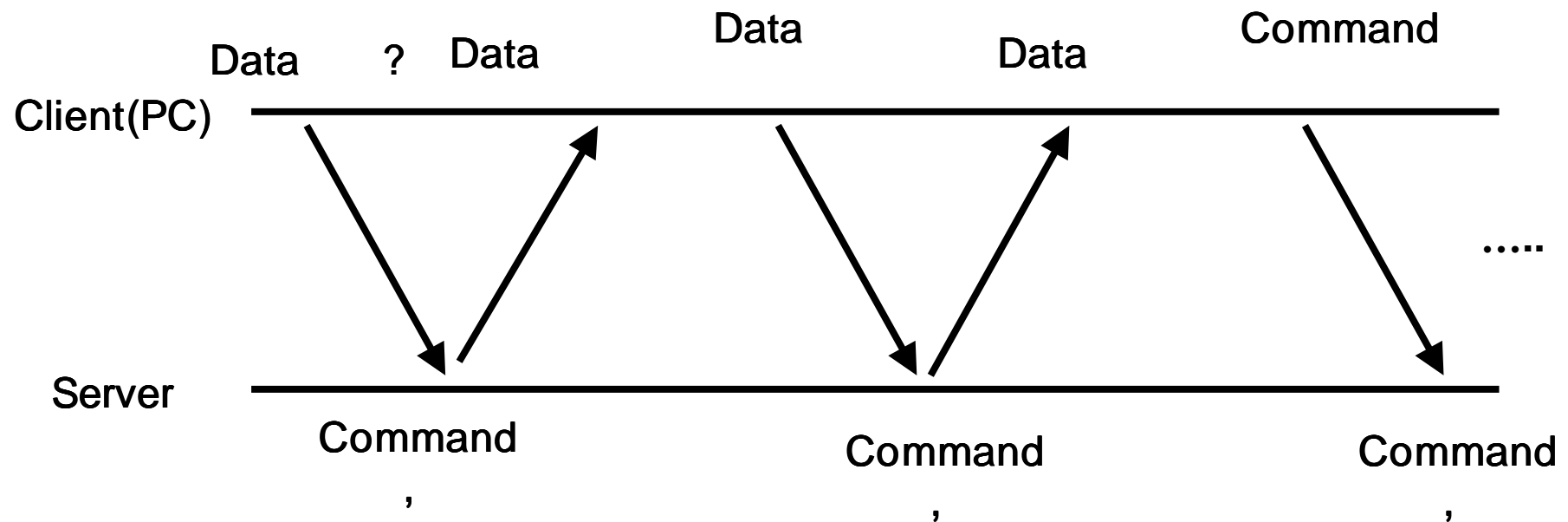

가 POS System

- : 가 POS System

- : HD1300(Serial)

- : 가 POS

가

, POS

POS

.

CALL

.

가 POS System

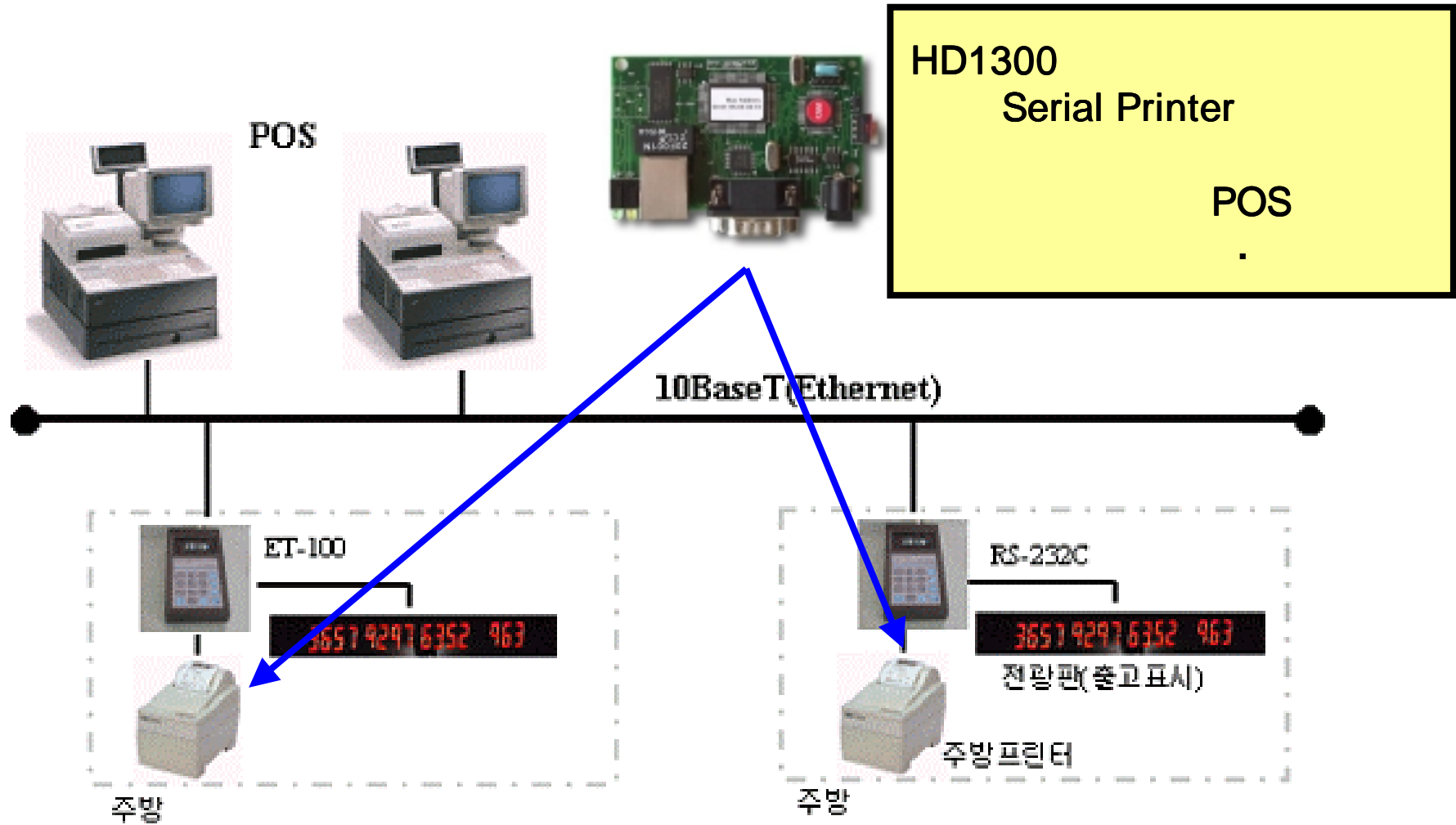

가 POS System

-

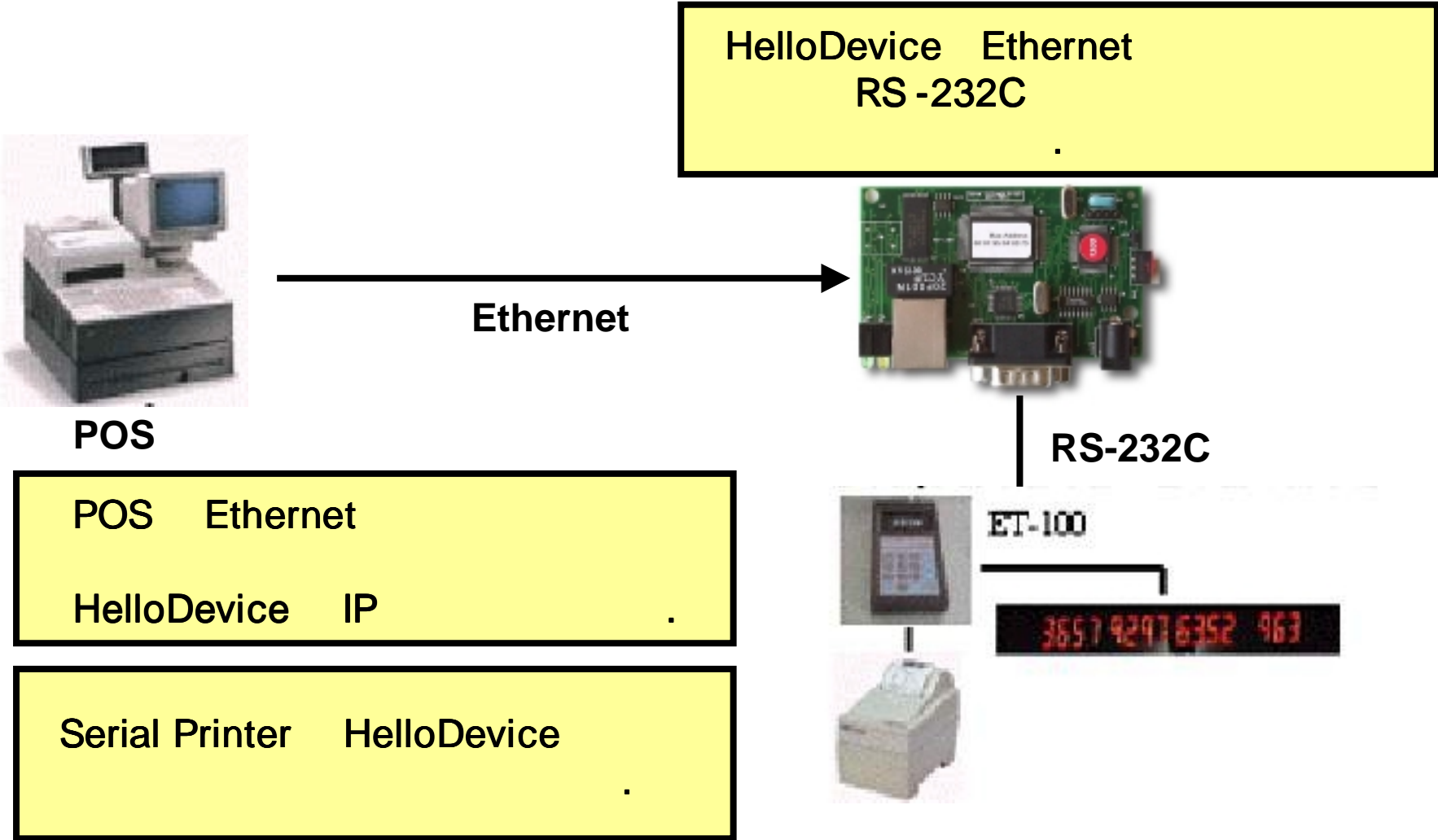

- : Cellular Phone
- : HD2310E
- : Cellular Phone
가

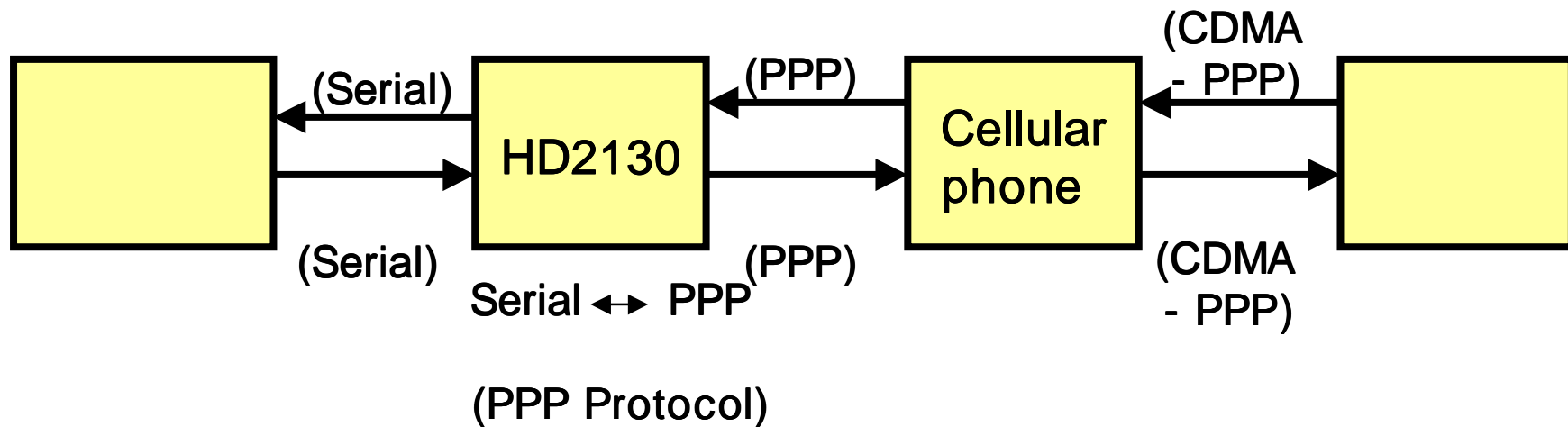



[Yellow box]

HD2310E

Cellular Phone

[Yellow box]

ISP

[Yellow box]

Serial

가
PPP
Protocol
ISP

CDMA PPP
Internet

PPP

[Empty box]